

OPERA® FLO AUTO
MATTRESS SYSTEM

Instructions and Technical Specifications

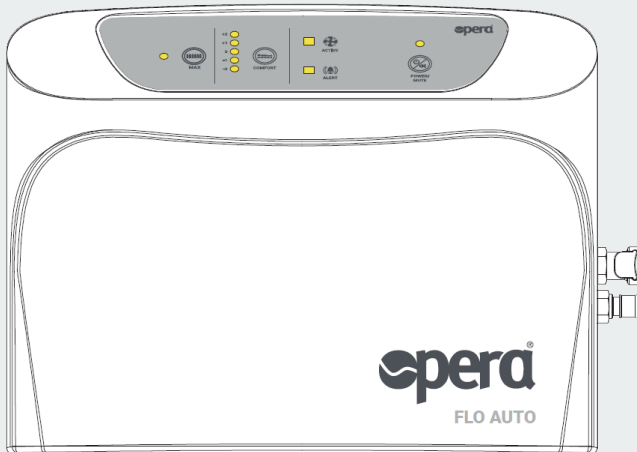

Contents

1.	Explanation of Symbols	3
2.	Safety Precautions	4
3.	Warnings	5
4.	System Package	6
5.	Power Unit Features	7
6.	Mattress and Power Unit Installations	9
7.	Program Settings	10
8.	Patient Transfer and Transport	11
9.	Emergency CPR Deflation	12
10.	Cleaning Instruction	12
11.	Routine Maintenance and Storage	13
12.	Troubleshooting	13
13.	Return for Service	15
14.	Warranty	15
15.	Product Specifications	16

Indications

This air alternating mattress system is designed for patients who endure pressure ulcer and potential patients who wish to reduce the likelihood of pressure ulcer. This device is intended to treat and prevent pressure ulcers by facilitating blood circulation and decreasing pressure of each tissues contact area. Always consult a physician or healthcare professional before using this mattress system. This anti-decubitus mattress system is mainly for high risk patient groups.

Contradictions

Certain patient conditions are not suitable for using this type of device such as fracture of unstable vertebrae and illness of unstable vertebrae. Always consult a physician or health professional before using this device.

The use of this system does not replace the regular repositioning, monitoring and, nursing of the patient.



Thank you for purchasing this anti-decubitus mattress replacement system. **Please read these instructions carefully before setting up and using the device.** Pay special attention to the warnings and other safety information. Use of genuine components is essential for optimal performance. If you do not fully understand all the instructions, safety precautions, and warnings, do not use this device. If you have questions, please contact Opera on 0333 222 8584.

1. Explanation of Symbols



Read information with this symbol carefully and urgently follow instructions. This information is safety-relevant.



This symbol indicates general hazards. There is danger to life and health.



Conformity mark in accordance with the European Medical Device Directives 93/42 EEC amended by 2007/47/EC.



Protected against ingress of solid foreign objects ≥ 12.5 mm diameter. Protected against vertically falling water drops.



Double Insulated (Class II) equipment.



Symbol for Type BF Applied Part Mattress according to IEC/EN 60601-1.



Indoor use only.



This product must be disposed of in a separate refuse collection in the European Union. Do not dispose of as normal domestic waste.



Read instructions.



Manufacturer.



Date of Manufacture.

2. Safety Precautions

2.1 Proper Operation

To ensure proper operation, please inspect and verify that all parts are set up properly and are anchored securely to the bed system. Verify that the mattress replacement system does not interfere with the bed frame function. Do not place anything on top of the power unit. Make sure power cord set is underneath the bed frame and does not pose a hazard.

2.2 Use of Linens

It is recommended to limit bed linens to a single layer in order to allow moisture to escape efficiently through the coverlet. Breathable incontinent pads are recommended for use with this mattress system.

2.3 Flammability Hazard



Avoid using this device near open flames, lighters, or cigarettes.

Flammability hazard exists. This device draws air from the surrounding environment. Thus, cigarette smoking may damage internal components.

2.4 Disinfection Between Patients

This system should be disinfected thoroughly between patients in order to avoid cross contamination.

2.5 Weight Capacity

Verify that the patient's weight, accessories, and this mattress replacement system, do not exceed the bed frame's manufacturer's recommended weight capacity.

3. Warnings

3.1 Side Rails



Use this mattress with side rails that meet bed rail regulations (BS EN 60601-2-52:2010) to ensure that the gap between the side rail and the top of the mattress is not large enough to pose risk of head or neck entrapment. Failure to do so could result in serious patient injury or death. If applicable, adhere to facility or local guidelines regarding entrapment regulations.

3.2 Do Not Disassemble



Do not disassemble the power unit if you are not a qualified technician. Please contact Opera on 0333 222 8584.

3.3 AP/APG Protection

This product is **not AP/APG protected**.

3.4 Periodic Repositioning

It is recommended that the patient be repositioned periodically while using this mattress.

3.5 Battery Replacement

Incorrect battery replacement may result in risk of explosion. Replace only with same or equivalent battery type recommended by the manufacturer.

3.6 Maintenance

If the equipment needs maintenance, contact Opera on 0333 222 8584 as soon as possible. For equipment that is no longer functional, make sure to follow national, state, and/or facility requirements for disposal of the unit.

3.7 Maximum Operating Temperature

The air mattress operates at a maximum temperature of 100 °F (37.7 °C).

3.8 Sharp Protrusions



Ensure that there are no protruding objects, sharp points, or bed springs under the mattress as these could puncture the air cells.

3.9 Disposal of Waste



This device must not be disposed of as normal household waste after the end of its service life. Contact your local waste recycling facility for further instructions.

4. System Package

4.1 Power Unit Package

Power Unit x 1

Power Cord x 1

Instructions For Use x 1

4.2 Mattress Package

Mattress replacement unit with coverlet x 1.

5. Power Unit Features

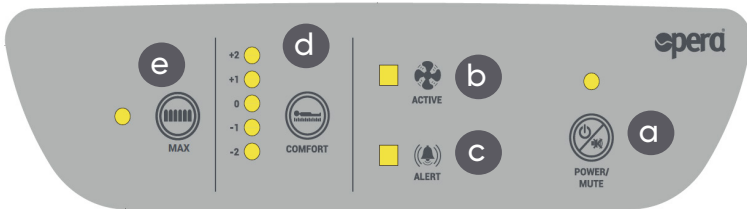

a. Power/Mute

Press button to turn on the power unit and the green LED will light. The LED will change to orange if abnormal power outage occurs and an audible alarm will sound to notify medical staff. You may press the button to mute the alarm or it will sound until power is restored or a rechargeable battery is discharged. The memory re-call function recalls the previous setting when the pump is turned off/on or after a power-outage.

b. Pressure Monitoring LED

Power unit features an integrated pressure sensor which monitors the mattress' internal pressure of the mattress every six seconds to ensure operation pressure relief and comfort to the patient.

The lighted LED indicates that the system is operating and the pressure sensor is monitoring the mattress' internal pressure.

c. Alert LED

This alert notifies medical staff the mattress has insufficient pressure. Audible alarm will sound for 15 seconds at each cycle and the indicator will stay on until the problem has been solved.

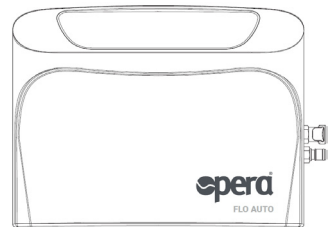

d. Comfort Adjustment

Simply press the button to adjust the patient's comfort from -2 to 2. Please adjust the comfort setting if the mattress is too soft or firm to suit each patient. Caregivers should always perform a hand check by placing their hands underneath patient's pelvis area to check if there is sufficient air support to ensure the patient is not bottoming out.

e. Max Inflate Mode

The max inflate mode will rapidly inflate the mattress to maximum pressure, allowing caregivers to perform daily nursing procedures. To cancel the max inflate mode, press the max inflate button again. The system will automatically change back to the previous comfort setting with alternating therapy after 20 minutes.

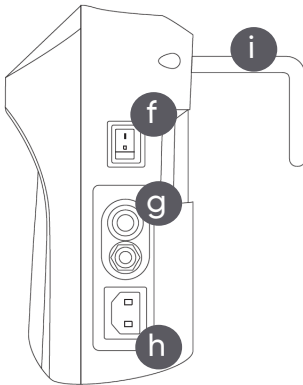

f. Rocker Switch

Power unit's main power switch.

g. Couplers

Quick release female couplers are used to secure mattress air hoses to the power unit.

h. Power Receptacle

Insert power cord set firmly into receptacle.

i. Hanging Hooks

Hanging hooks are designed to hang the power unit on almost any foot board.

j. Convenient Handle

The handle provides additional gripping surface for the user to carry the power unit.

k. Fuse

Fuse Holder

l. Air Filter and Cap

We recommend that the filter is kept clean to ensure optimal performance of the power unit.

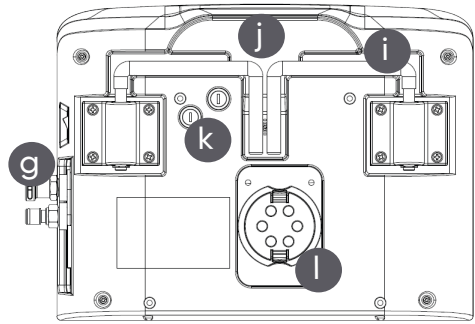

6. Mattress and Power Unit Installations

6.1 Remove Existing Mattress

Remove existing mattress from the bed frame.

6.2 Secure Mattress Replacement

Place mattress replacement on the bed frame with the foot symbol at foot end. Secure the mattress at each side using anchor straps. Ensure that the anchor straps do not interfere with any moving parts of the bed frame before proceeding to the next step.

6.3 Secure Power Unit

Secure the power unit on to the foot board using hanging hooks.

6.4 Connect Hose Couplers

Firmly connect the air hose couplers to the couplers on the power unit.

6.5 Check CPR Pull Cord

Unzip mattress cover and inspect CPR latch is fully inserted into the socket. It should arrive fully inserted when first purchased, but it is worthwhile checking, especially when re-installing the mattress.

6.6 Power Up Unit

Plug the power unit into an electrical outlet, and turn on the main power rocker switch on the right side of the power unit.

Press power button on the control panel to inflate the mattress system. Please wait for approx. 30 seconds until the power unit is ready before making any program adjustment.

6.7 Wait for Inflation

Wait approximately 30 minutes for the mattress to inflate fully before allowing the patient to lie down on the mattress.

6.8 Ensure Patient Comfort

Perform the firmness and hand checks in section 7. Program settings before leaving the patient for long periods of time.

7. Program Settings

7.1 Adjusting Firmness

Place the patient in the centre of the mattress. Adjust the mattress' internal pressure according to the patient weight by using the lockable patient weight knob on the control panel of the power unit. If the mattress is too soft or too firm, increase or decrease the mattress' internal pressure one increment at a time and wait for the system to stabilise before making another change. Continue this process until comfort is achieved.

7.2 Perform Hand Check

Caregivers should always perform a hand check by placing their hands underneath the patient's pelvis area to check if there is sufficient air support to ensure the patient is not bottoming out.



Tucking the bed sheet in too tightly may reduce the effectiveness of the system.

8. Patient Transfer and Transport

8.1 Transfer

It is recommended to have the mattress system fully inflated during the transfer process. To do this increase the comfort setting to +2. Make sure the bed is secured before proceeding.

8.2 Transport

In the event of a patient transport, two options are available.

1. Detach the mattress' air hose couplers from the power unit's quick release couplers and connect the two air hose couplers together to retain air in the mattress. The mattress will stay inflated for approximately 2 hours, depending on the patient's weight.
2. Unplug the power unit's power cord from the wall outlet and the mattress should stay inflated for approximately 40 - 50 minutes. This mattress system also has a safety foam base underneath the air cells to support the patient for a short period of time in case of deflation. To resume normal operation, please follow the instructions beginning in Section 6.2.

9. Emergency CPR Deflation



In the case of emergency, pull hard to remove the mattress' CPR latch and detach the quick release coupling from the control unit for emergency deflation and turn off the power unit by pressing the power/mute button on the control panel at the same time for emergency deflation. The air will discharge from the mattress with the patient's own weight. To resume normal operation, simply re-insert the CPR latch securely, press the power/mute button again and reset the patient weight. See instructions in Section 6.

10. Cleaning Instruction

The air mattress and power unit must be cleaned thoroughly between patients to avoid cross contamination. The following is a suggested guideline. Be sure to follow local infection control policies.

Regular cleaning can be performed at bedside with a disinfectant followed by drying with a clean dry cloth. Use only mild detergents to clean the coverlet and the mattress. Any appropriate non-phenolic cleaning agent may be used for heavy soiling from urine, blood or other bodily fluids. Please ensure that the air mattress and coverlet are completely dry before letting the patient lie on the surface again.

The recommended wash temperature is 70°C, at 95°C the shrinkage rate is 1% higher and the colour might run insignificantly.

Always replace the coverlet before using the mattress. If the coverlet is not properly fitted to the mattress the hybrid alternating pressure cells may move. There is also a high risk of cross contamination if the mattress is used without a coverlet.

Do not use electric or tumble dryers. Do not iron.



Always unplug the power unit before cleaning. Routine cleaning of power unit can be done by wiping down with damp cloth, using disinfectant or mild detergent. Never spray liquids directly on the unit itself.

11. Routine Maintenance and Storage

Remove air filter from the rear panel of the power unit by opening up the filter cap. Inspect the filter for dirt or dust, and clean it with mild soap and water. Reinsert the dried air filter after cleaning and ensure that the cap is secure. If a replacement is needed, contact Opera on 0333 222 8584.

Only disinfected and dry systems should be stored. Disconnect the air hoses from the power unit. Roll up the mattress starting from the head end and working down toward the foot end. Use the straps to secure it and store in clean plastic or other storage bag. Store in a cool, dark place.

12. Troubleshooting

Fault	Inspection Procedure	Remedy
Power unit is not working.	Check if power cord is firmly plugged into both the control unit and the electrical outlet.	Secure power cord into control unit and/or electrical outlet.
	Check if the power switch is in the <u>on</u> position.	Turn power switch to <u>on</u> position.
	Check if the power surge has shut down the power unit.	A power surge may overload the circuitry temporarily. Turn the unit off, and check the fuse for damage. Turn the unit on again with normal procedure.
	Make sure there is no power failure.	Turn on and operate the unit after power is restored to the facility or home.
	Power unit does not respond to possible solutions.	Please contact Opera on 0333 222 8584 for assistance.
Low pressure alert does not go out in 30 sec. after system starts.	Possible control failure.	Please contact Opera on 0333 222 8584 for assistance.
Alert LED is lit during operation.	Check if there is leakage in air tubes* or air cells.	

<p>Power unit is working, but mattress replacement is not inflating</p> <p>and/or</p> <p>Bottoming out is occurring</p> <p>and/or</p> <p>Patient leaves a deep indentation at the contact area which does not return back to its original shape.</p>	Check CPR Pull Cord.	Unzip mattress cover and inspect CPR latch is fully inserted into socket.
	Check if mattress' air hose couplers are properly connected to power unit's quick release couplers.	Secure air hose couplers firmly into place.
	Verify that patient weight setting is correct.	Increase or decrease weight setting until appropriate pressure is reached.
	Inspect air filter for dust and dirt.	Clean or replace air filter.
	Lift mattress coverlet up to check if air cells are connected correctly.	Make sure all air cells are properly linked to air supply.
	Lift mattress coverlet up to check if air tubes are kinked or obstructed.	Check and adjust air tubes positions.
	Check if air cells are cut or cracked	Please contact Opera on 0333 222 8584 for assistance.
Alternating or Constant mode is not available.	Possible control failure.	Please contact Opera on 0333 222 8584 for assistance.
Patient's wounds are not responding to pressure relief (reddening of skin).		Contact your physician and/or nursing service immediately.

13. Return for Service

Service and repair must be performed by Opera authorised technicians or representatives. Please contact Opera on 0333 222 8584.

14. Warranty

We warrant the product to be free from defects from the date of purchase.

Please inspect all accessories when you purchase our product. If there is any damage or missing accessories when you receive the product, please ask for a replacement from Opera on 0333 222 8584 within three days of purchase.

The warranty period for the products are according to the regulations in your country, the minimum period is 2 years from date of purchase for the power unit and 2 years for the mattress and the coverlet. The warranty coverage of any product is contingent up on its purchase from Opera.

Warranty coverage will not be extended to any product on which the production lot number has been removed or defaced on which repair has been attempted by any person or agency not authorized by our company or if in the sole opinion of our company that the system shows evidence of tampering, abnormal or unreasonable abuse, negligence, accident or operation without regard for the restrictions specified in the instructions which accompany the system. This warranty does not cover normal maintenance such as cleaning, adjustment, lubrication, and updating of equipment or parts. If the damage is a result from improper operation, a reasonable service fee and part cost will be charged.

The warranty stated above is the only warranty made and is in lieu of all other warranties whether expressed or implied, including any warranty of merchantability or fitness for a particular reason, we will not be liable for consequential or incidental damages of any kind.

15. Product Specifications

System Name	Flo Auto Mattress System
Power Unit (Air Pump) Model	SR366
Mattress Dimension	2000 x 900 x 180mm (7" depth) 2000 x 1050 x 180mm (7" depth)
Number of Air Cells	20 Cells
Power Control Unit Dimension	295 x 225 x 120mm
Material	Power Unit - Plastic Case rated UL 94V-0 Mattress Cell - 100% nylon with TPU lamination Coverlet - Quilted Nylontaffeta Backing
Power Input	220 - 240Vac, 50Hz, 0.2A
Power Consumption	Normal Operation: Max 20W
Power Control Unit Weight	2.5 kg
Fuse Rating	T1A 250V
Electrical Classification	Class II Type BF applied part mattress.
IP Code	IP21
Operation Mode	This system is not AP/APG Protected. Continuous operation.
Power Cord Set	H105VV-F or H05VVH2-F, 2 x Min. 0.75mm ² , 250Vac
Operating Conditions	Temperature: 5°C - 40°C Humidity: 15% - 90% Atmospheric Pressure: 700 - 1060hPA
Transportation & Storage Conditions	Temperature: -25°C - 70°C Humidity: 0% - 90%
NiMH Battery	3.6Vdc 600mAh
IEC/EN Test Standards	Safety: IEC/EN 60601-1_v3.1 EMC: IEC/EN 60601-1-2_v4
Maximum Weight Capacity	180 kg

Notes

Notes



Azure House, Connaught Road, Kingswood, Hull, HU7 3AP

0333 222 8584 | support@operabeds.com | operabeds.com

Version 2 | Published in August 2022